



SY125FR & SY200FR

2008
MANUEL
DE L'UTILISATEUR /
USER'S MANUAL /



Congratulations!

You have just bought a SCORPA SY 125 FR AND SY 200 FR. Welcome in the family of the SCORPA's customers.

This motorbike is the fruit of the experience of the high level of trial and of advanced technology. As all products of our range, it benefits from the expertise of our suppliers and from the high level of quality in the manufacturing of our motorbikes, which is well known in the world of trial.

The use of SY 125 FR AND SY 200 FR motorbike requires the greatest precaution in order to take advantage of the abilities. It is very important to read this user manual before starting the bike. In this, you could find the pieces of information about the maintenance and the controls of your SCORPA SY 125 FR AND SY 200 FR. First and foremost you will find all security instructions to avoid the risks and the danger of motorbike-riding.

Moreover, the advice given in this manual will help you to keep your motorbike in perfect working order. If necessary, do not hesitate to go and see your dealer SCORPA. The company SCORPA wishes you would find pleasure in riding your SCORPA SY 125 FR AND SY 200 FR. Do not forget the security must always be the first preoccupation.

Thank you very much.



SCORPA SY 125 FR and SY 200 FR USER'S MANUAL

This document belongs to SCORPA. It cannot be distributed, copied or used without SCORPA's authorization.



Those symbols give you pieces of information about the most important notions. They are described here:



DANGER!

BE CAREFUL, IT CONCERNS THE SECURITY



WARNING

If the instructions given are not respected, it can have serious consequences for the health of the rider, of third party and of the people who work on the bike.

WARNING

This symbol concerns the indications, the precautions and the instructions which must be followed to avoid the deterioration of your vehicle.

NB

This symbol introduces pieces of information which will allow you to maintain your bike.

NB : The user manual takes part in the bike and must be given to the new owner in case the bike is sold. SCORPA is always working to develop and to improve its products, so that you could find a few modifications in this manual in comparison with your bike.



CONTENT

1	SECURITY	6
2	DESCRIPTION OF THE VEHICLE.....	7
2.1	Left sight of the motorcycle.....	7
2.2	Right sight of the motorcycle.....	7
2.3	HANDLE BAR CONTROLS	8
3	CONTROLS AND INSTRUMENTS.....	8
3.1	Controls and electric switches.....	8
3.1.1	Light switches.....	8
3.2	Mechanical controls and indicators.....	9
3.2.1	Clutch lever	9
3.2.2	Gearshift lever	9
3.2.3	Front brake lever	9
3.2.4	Rear brake pedal.....	10
3.2.5	Choke handling.....	10
3.2.6	Antitheft lock.....	10
3.3	Fuel tank	11
3.3.1	Fuel tank cap.....	11
3.3.2	Fuel.....	11
3.3.3	Fuel cap	12
3.4	Side stand.....	13
4	CHECK LIST BEFORE USE	13
5	INSTRUCTIONS AND ADVICES BEFORE STARTING THE BIKE	15
5.1	Starting (cold engine)	15
5.2	Start (when the engine is already warm).....	15
5.3	Gear change	16
5.4	Fuel consumption reduction :	16
5.5	Engine lapping	16
5.6	Parking.....	17
6	MAINTENANCE AND LITTLE REPAIRING	17
6.1	Tools.....	17
6.2	Regular lubrications and maintenance	17
6.3	Spark plug check.....	19
6.4	Engine oil.....	20
6.5	Engine oil level check.....	20
6.6	Air filter cleaner.....	21



6.7	Carburetor adjustment	22
6.8	Play of the valves	22
6.9	Wheel-axle units.....	22
6.9.1	Front wheel removal	22
6.9.2	Front wheel fitting.....	22
6.9.3	Rear wheel removal	22
6.10	Tires.....	23
6.10.1	Check of the conditions and of the treads depth of the tires	23
6.10.2	Pieces of information about the tires.....	23
6.11	The spoke wheel	24
6.12	Transmission chain	24
6.12.1	Check of the tension	24
6.12.2	Setting	24
6.12.3	Lubrication	25
6.13	Adjustement of the clutch lever loose.....	25
6.14	Brakes.....	25
6.14.1	Adjustment of the brake levers loose	25
6.14.2	Adjustment of the rear brake pedal loose.....	26
6.14.3	Pad wear control.....	26
6.14.4	Brake fluid level control	27
6.14.5	Brake fluid change	27
6.15	Lubrifications	28
6.15.1	Cable	28
6.15.2	Brake pedal, gearshift levers	28
6.16	Side stand.....	28
6.17	Rear suspension	29
6.17.1	Inspection	29
6.17.2	Adjustment.....	29
6.18	Front fork and steering	29
6.18.1	Front fork check.....	29
6.18.2	Check of the functioning of the fork.....	29
6.18.3	Check of the steering	29
6.19	Check of the wheel bearings.....	30
6.20	Replacement of electric elements.....	30
6.20.1	Replacement of a light bulb	30
6.20.2	Replacement of the indicators bulbs	30
6.20.3	Replacement of the rear light bulb.....	30
6.21	Diagram of breakdowns and dedicated checks	31



6.21.1	Fuel	31
6.21.2	Compression.....	31
6.21.3	Ignition	32
7	CARE AND STORING OF THE BIKE	32
7.1	Care	32
7.1.1	Before cleaning.....	32
7.1.2	Cleaning.....	32
7.1.3	After the cleaning	33
7.2	Putting away	33
8	DESIGN FEATURES	34
9	ELECTRICAL WIRINGS INSTALLATION	36
9.1	Passage and connection of the main electrical wiring.....	36
9.2	Connection of the other parts.....	37
9.2.1	Front stop light contactor.....	37
9.2.2	Rear light contactor.....	38
9.2.3	Klaxon	38
9.2.4	Direction light generator unit	39
9.3	Rear light.....	40
9.4	Reassembly and passage of cables.....	40



1 SECURITY

The motorbike is a really particular vehicle, which gives incomparable sensations of power and freedom. However, it is very important not to forget that the best motorbike has only two wheels, so that it cannot escape from physical laws.

As a consequence, the vehicle has to be maintained in the best work order. That is exactly the same for the rider. SCORPA recommends you to respect the laws of the country where you are riding, not to ride under the influence of alcohol or of drugs. To be in a great form, without extreme fatigue, can allow you a safe driving and quick reflexes.

Riding motorbike implies that you wear sturdy bike clothes. The helmet, the clothes (of leather or of reinforced synthetic materials), solid shoes (preferably bike boots) and gloves are essential for the rider.

Wearing such equipments must not lead to change of the way of riding, and the security instructions must be respected.



2 DESCRIPTION OF THE VEHICLE

2.1 Left sight of the motorcycle

- | | | | |
|----------------------|----------------------|--------------|---------------|
| 1. Head light | 2. Lock of direction | 3. Fuel tank | 4. Rear light |
| 5. Sail cam adjuster | 6. Shift Shaft | 7. Fuel Tap | |

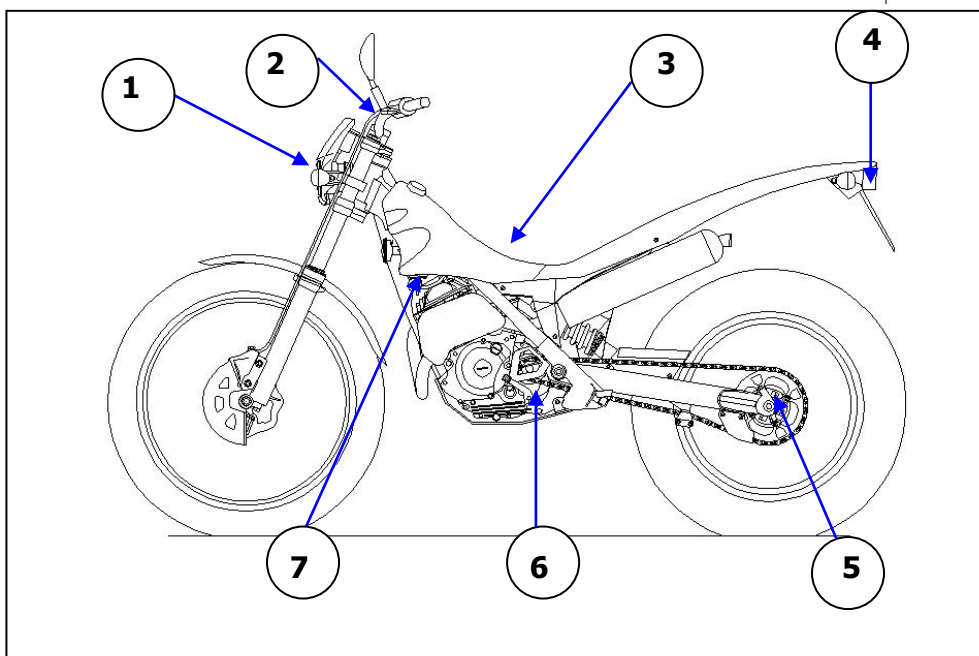

2.2 Right sight of the motorcycle

- | | | |
|-------------------|------------------------|----------------|
| 8. Air filter box | 9. Pedal of rear brake | 10. Side stand |
|-------------------|------------------------|----------------|

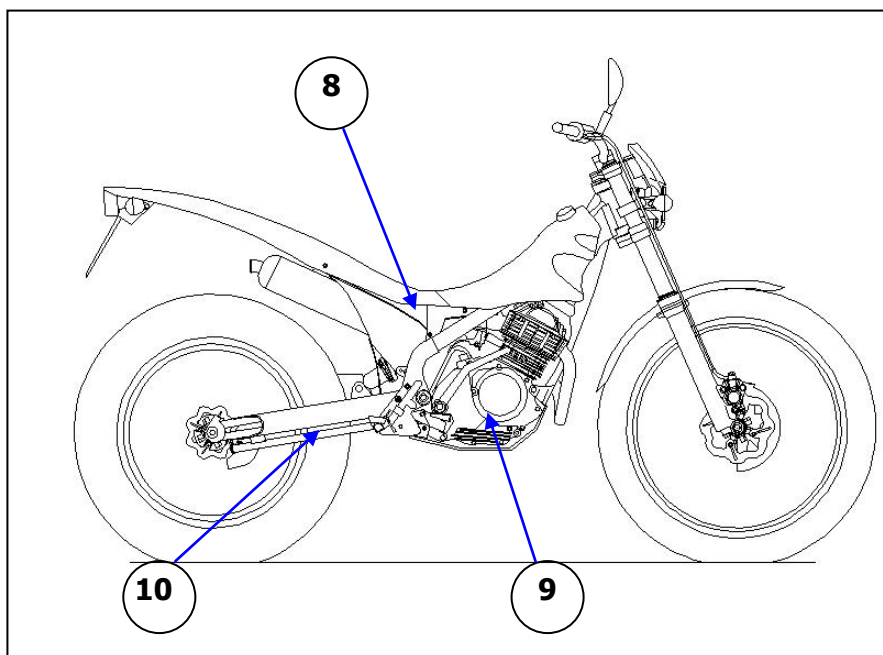



2.3 HANDLE BAR CONTROLS

- | | | |
|------------------|-------------|---------------------------|
| 1. Clutch lever | 2. Starter | 3. Steering wheel locking |
| 4. Brake lever | 5. Throttle | 6. Switchers |
| 7. Left handgrip | | |

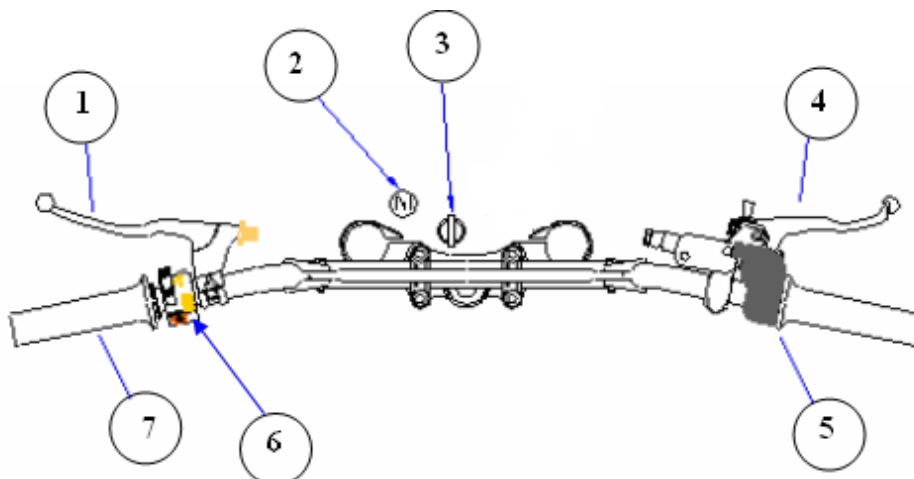

3 CONTROLS AND INSTRUMENTS

3.1 Controls and electric switches

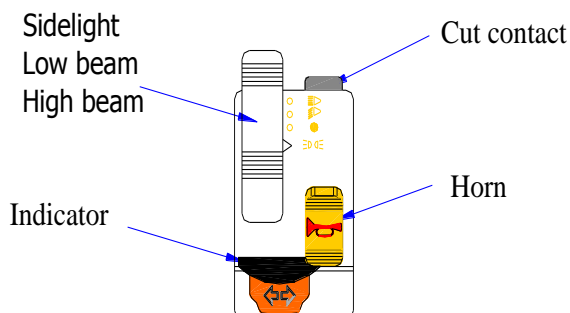

3.1.1 Light switches

This part is made up of four controls :

- Side light / low beam / high beam : $\diamond \ni \ni / \ni / \ni / \ni$
You put the control on " \ni " to switch on the high beam, on " \ni / \ni " to switch on the low beam. The sidelight is shown by the symbol " $\ni \ni \ni$ "
- Indication control : " $\Leftarrow \Rightarrow$ "
In order to indicate a turn to the left: push the control to the left, towards the symbol " \Leftarrow ".
In order to indicate a turn to the right: push the control to the right: towards the symbol " \Rightarrow ".

NB: when the indicators control is released, it goes back to the middle. In order to turn the indicators off, press the control when it is back in central position.
- Horn control : the horn rings when you push this control.





- Cut contact of the engine : "⊗" : Press this button in case of emergency as a fall or a blocking of the brake cable or the accelerator. It has the effect of cutting the engine.

3.2 Mechanical controls and indicators

3.2.1 Clutch lever

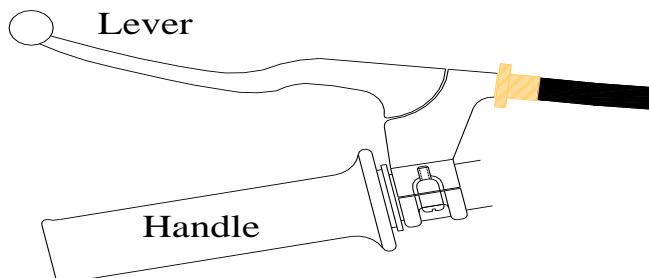

The clutch lever is located on the left side of the handlebar. It is fixed near the left handgrip. To declutch, pull the lever towards the handgrip. To engage, just release the lever. If you would like to obtain smoothly driving, the solution is to pull the lever very quickly and to release it very progressively.

3.2.2 Gearshift lever

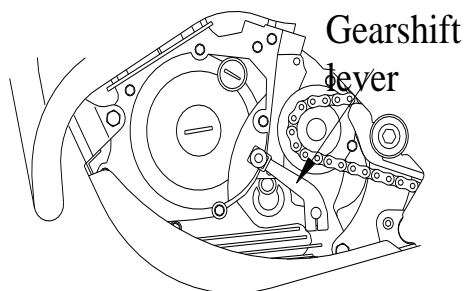

The gearshift lever is situated on the left side of the bike, at left toes level, when the heel rests on the left rest-foot. The use of the gearshift lever must be done only when the engine is released. That means the clutch lever is pulled towards the handgrip. The gearshift lever allows choosing one of the 5 gears of the gearbox.

3.2.3 Front brake lever

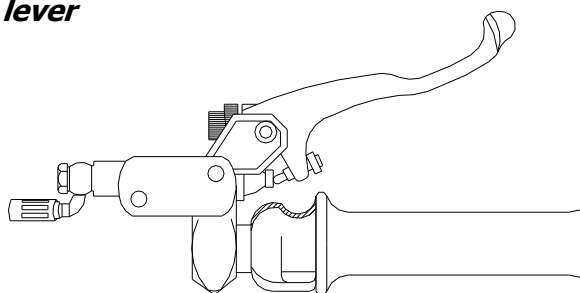

The front brake lever is situated on the right side of the handlebar. To operate the front brake, pull the lever towards the handgrip.



Precautions in the handling of the brake levers.

The brake levers handling must be accompanied by high precautions. In fact, a wheel lock often means the fall of the rider and its bike. That is one of the main reasons why the motorcyclists can fall. It is recommended to pull the lever as progressively as possible.

3.2.4 Rear brake pedal

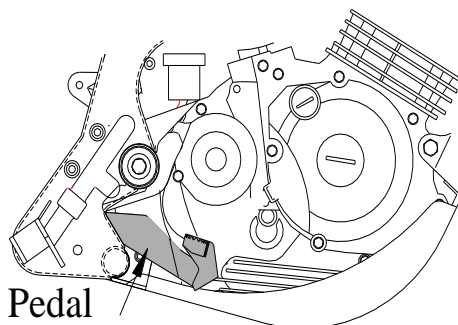

The rear brake pedal is situated on the right side of the bike, at the front of the right foot level, when the heel rests on the right rest-foot. To operate the rear brake, push the pedal towards the ground.

Precautions in the rear brake handling

As told for the front brake lever, be careful not to operate too strongly the rear brake pedal. Otherwise it can lead to the lock of the rear wheel and the fall of the rider.

3.2.5 Choke handling

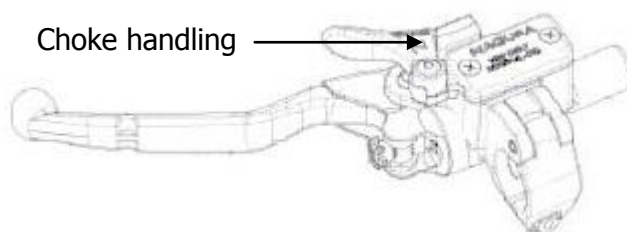

As the engine is cold, it may need to have recourse to the choke, in order to make the air / fuel mixture richer. Pull the control to open the choke and enrich the mixture. Push the control towards the ground to close the choke and to impoverish the air / fuel mixture.

3.2.6 Antitheft lock

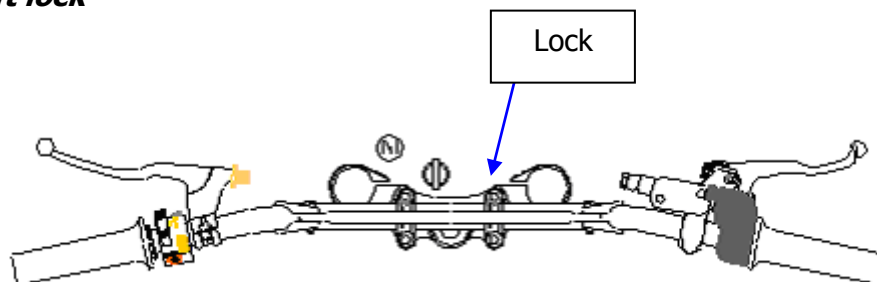



Locking the direction: insert the key in the lock and turn it a quarter of turn towards left. Push it and, while maintaining it pushed, turn it a quarter of turn towards right. Withdraw the key, the direction is locked.

Unlocking the direction: insert the key in the lock and turn it a quarter of turn towards left: the lock goes up. Turn the key a quarter of turn towards right to withdraw the key and put it in your pocket.



WARNING

Do not let the key in the key while riding. Always withdraw it before starting using your bike.

3.3 Fuel tank

3.3.1 Fuel tank cap

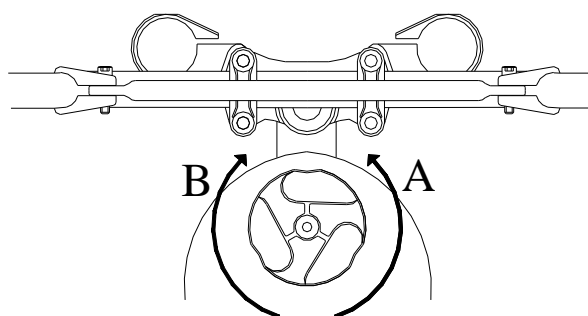

To remove the cap from the fuel tank, turn it anticlockwise (in the direction A), until it can be taken away. As soon as the cap is not screwed on the fuel tank, you can take it.

To put it back, turn the cap clockwise into the fuel tank (in the direction B).

When the tightening becomes harder, it is important to give one more effort, in order to be sure the fuel cap is tightened enough.



WARNING

It is very important to check that the cap is tightened enough before starting the engine and riding the bike.

3.3.2 Fuel

The recommended fuel is only lead-free high octane petrol. The highest capacity of the fuel tank is 2,9 litres and the reserve is 0,5 L.

WARNING: the use of another fuel than this recommended by the manufacturer can cause serious deteriorations on the engine and on the exhaust system. SCORPA will not be responsible for any problem in that case

Before each use, check that the quantity of fuel is sufficient. In case it is not, complete in the tank. The filling up must absolutely not exceed the maximum level. Otherwise, the fuel contained in the tank could easily flow along it.

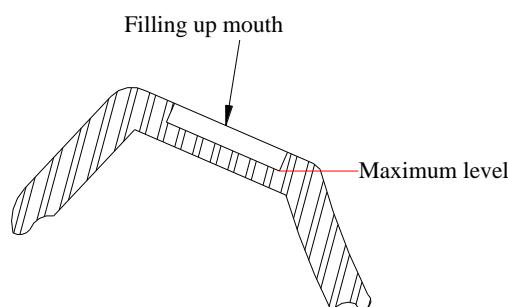



WARNING

The fuel tank must not be too much filled. In fact, as the engine is very close, the overflowing would be increased by the expansion due to the warmth.

The filling up has to be operated with a lot of precautions. There must not be fuel on the engine. This is recommended not to fill the fuel tank near a flame or near a source of heat.

WARNING :

When a little amount of fuel overflows on the tank during the filling up, wipe it thanks to a sweet, soft and dry duster, in order to avoid to damage plastic, polished and painted parts.

3.3.3 Fuel cap

Its aim is to control the flow of fuel from the fuel tank to the carburettor, as the rider wants it to be regulated. This tap contains a filter, which role is to hold back the particles which could damage the engine. This diagram shows the three different possible positions. The chosen one is pointed out thanks to the drawn arrow.

There are three different positions :

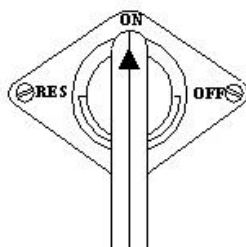

- OFF : The tap is off and the fuel is not able to flow to the carburetor. The tap must be on 'off' when the engine does not run.
- ON : the tap is running and the fuel can flow to the carburetor. The tap must be on 'on' before trying to start the engine and during the use of the bike.
- RES (Reserve): when the fuel tank is almost empty and the fuel does not flow anymore, put the tap on the position 'res.'. This system is expected to allow you to join the first filling station. Fill up the fuel tank as soon as possible. When the tank is full, put back the tap on the position 'on'.



3.4 Side stand

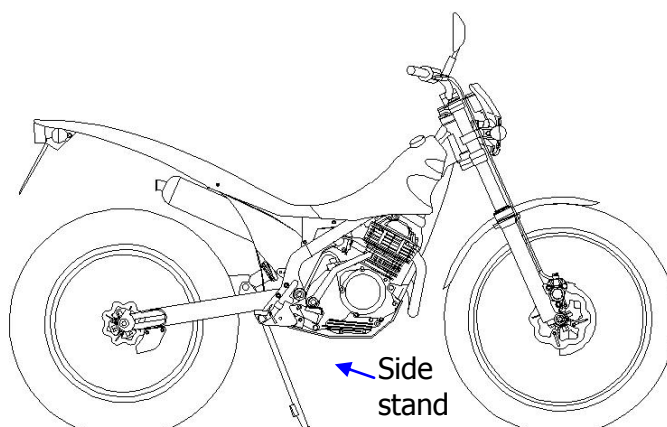

The side stand is fixed to the swinging arm on the right side of the bike. It automatically folds back as soon as the bike is put vertical.



WARNING

During the fallback of the side stand, take care not to let one of your limbs near the mechanism and be sure the third parties do so. That is the way to minimize the risks of plucking. However the stand includes a protective rubber.

4 CHECK LIST BEFORE USE

The owner is responsible for the condition of his vehicle. The bike may suffer damages during the use and during the parking too (bad weather or acts of vandalism for example). The damaging of parts which take part in the security can have very serious consequences. SCORPA recommends you to check visually those sensitive spots. If necessary, a more detailed check is naturally advocated. In case you have any doubt, do not hesitate to get in touch with your dealer.

CHECK POINT BEFORE USE

Heading	Check points
Fuel	<ul style="list-style-type: none"> Fuel level check. Filling up if necessary. Fuel hose check to detect a possible leak.
Engine oil	<ul style="list-style-type: none"> Engine oil level check. If necessary, filling up to the recommended level, with the indicated oil: <i>100% synthesis-ester-SAE 10w40.</i> Visual check to detect a possible leak.
Front brake	<ul style="list-style-type: none"> Check of the functioning. In case the brakes are soft or spongy, ask your dealer to bleed the circuits. Check of the play of the lever. Adjustment if necessary. If necessary filling up . Check of the circuit to find a potential leak.



Rear brake	<ul style="list-style-type: none"> • Check of the functioning. • In case the brakes are soft or spongy, ask your dealer to bleed the circuits. • Check of the play of the lever. • Adjustment if necessary. • If necessary filling up. • Check of the circuit to find a potential leak. 	
Throttle	<ul style="list-style-type: none"> • Make sure of the functioning progressiveness. • Check of the play of the accelerator cable. • If needs be, ask your dealer to adjust the play, and to lubricate the cable and the housing of the accelerator handle. 	
Clutch	<ul style="list-style-type: none"> • Check the functioning • Check of the play of the lever • Adjustment if necessary 	
Chain	<ul style="list-style-type: none"> • Check of the tension. • Adjustment if necessary. • Check of the condition. • Lubrication if necessary. 	
Wheels and tyres	<ul style="list-style-type: none"> • Check of the condition. • Check of the depth of the treads. • Check of the air in the tires. • Bring back to the recommended pressure if necessary. 	
Gearshift lever	<ul style="list-style-type: none"> • Make sure of the functioning progressiveness and regularity. • Lubrication of the rotating parts if necessary. 	
Brake levers and clutch lever	<ul style="list-style-type: none"> • Make sure of the functioning progressiveness and regularity. • Lubrication of the rotating parts if necessary. 	
Frame fastenings	<ul style="list-style-type: none"> • Check of the nuts and screws tightening. • Tighten if necessary. 	
Lights, signalling and electric contacts	<ul style="list-style-type: none"> • Check the functioning • Adjustment and correct if necessary 	

NB : It is strongly recommended to check all those points before each use. It only takes a few minutes and the security depends on it.



WARNING

In case there still is a problem after the adjustments, fillings and lubrications please make it check by your dealer before starting or using the bike.



5 INSTRUCTIONS AND ADVICES BEFORE STARTING THE BIKE



WARNING

Before using the SY 125 FR AND SY 200 FR, it is recommended to familiarize yourself with the engine and verify all of the functional commands in a non-hazardous area. When in doubt, refer to the SY 125 FR AND SY 200 FR manual and if need be your local dealer.

The engine never must be started in a closed area or room, even for a very short period of time. The exhaust gases are very toxic. Some of them are colorless and odorless, but can cause very serious suffocations (even fatal).

5.1 Starting (cold engine)

Before you start the engine, you have to put the gearbox in neutral position for security reasons :

- The gearbox is placed on neutral
- If the bike is in gear, the clutch lever must be pulled and the side stand folded up.

1. Turn the tap towards to 'ON' :

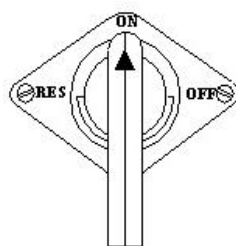

2. Pull the choke lever and release the accelerator handling :

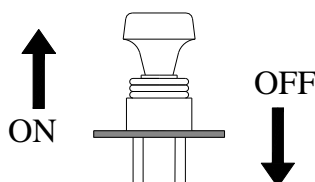

3. Spread the kick-starter.
4. Place your right foot on it and step very violently on it towards to the ground.
5. If the engine does not start, operate the two last indications again.
6. As soon as the engine starts, release the first half of the choke lever.
7. When it is warm enough, release totally the choke lever.

NB : you can consider that the engine is warm enough when it accelerates well, even when the choke is totally released.

WARNING: in order to improve the useful life of your vehicle, make sure the engine is not excessively accelerated until it is warm enough !

5.2 Start (when the engine is already warm)

The process is the same as this with a cold engine, but you do not have to use the choke here.



5.3 Gear change

The gearbox allows you to control the power transmitted to the rear wheel. That is very useful for the hill starts, the accelerations, the hills and the bends...

This diagram shows the way you must use to change the gears thanks to the gearshift lever.

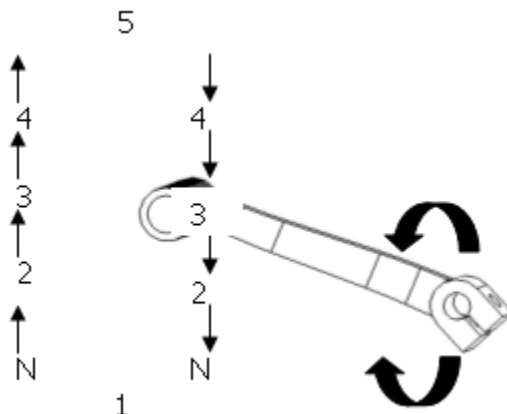

WARNING :

- It is recommended not to ride on the neutral for a too long time, especially when the engine does not run. Do not tow the bike for long distances, even on neutral. The lubrication of the gearbox is only sufficient when the engine runs. The problem is that a lack of lubrication will damage seriously the gearbox, even the engine of your bike.
- It is essential always to operate the clutch lever when you change the gears. Otherwise you will damage the gearbox, the engine and the transmission. Those parts are not conceived for such shocks and stresses, caused by the change in force of the gears.

5.4 Fuel consumption reduction :

The fuel consumption directly depends on the way you ride. Despite everything, a few tricks can help you to save up in this field :

- Release the choke as soon as possible.
- Change quickly the gears, without letting it rev hard during the acceleration.
- Do not accelerate needlessly during the deceleration or during the stops.
- Stop the engine when the traffic jam is long enough, or in front of a level crossing.

5.5 Engine lapping

The length of the bike's use life depends on the first 12 hours of use. That implies you have to respect scrupulously the following indications. During the lapping, all parts are new and must grind each other. The fragility of the parts during this period imposes not to subject them to violent shocks and important stresses for a long time.

.0 à 6 hours

Avoid accelerating more than a third of the throttle for a long lapse of time.

.6 à 12 hours

Avoid accelerating more than an half of the accelerator handling for a long period.

.At 12 hours

Replace the engine oil and clean the oil filter element.

.After 12 hours



The running-it is complete. You also can use the bike in the normal conditions, which are given in this manual, check wheels axles, engine and fork bolts as described.



WARNING: If a problem appears during the lapping, SCORPA recommends submitting the matter to your dealer as soon as possible.

5.6 Parking

When the bike is parked, the control of the fuel tank tap has to be turned to 'OFF'.



WARNING

- The hot engine and exhaust pipes could cause very serious burns to the children or to the pedestrians. Therefore it is really imperative to park the bikes in a way which help to prevent the people from burning themselves with those hot metallic parts.
- Take care to the area where you decide to park the bike.

6 MAINTENANCE AND LITTLE REPAIRING

A good motorbike rider is first and foremost expected to worry about the security. Those precautions begin by taking care about the 'active security'. That means that the rider has to respect the indications given in this manual about the checks, the maintenance, the adjustments and lubrications. The different checks are listed in the paragraph which title is '**CHECK LIST BEFORE USE**'. The other indications are going to be given to you in the current paragraph.

NB : All pieces of information given in this manual are adapted for the normal conditions of use and ride. Each owner is expected to adapt all values and frequency for his way of driving and for the particular using conditions of his vehicle. If the use can be considered as sporting or intensive, or if the atmospheric and area conditions are bad, the frequency of checks, maintenances and lubrications must be shortened.



WARNING

If you do not master the techniques enough, or if you do not have the required tools, it is preferable for you to leave the work to your dealer.

6.1 Tools

In most operations are only used usual tools. So they often can be bought in simple equipment or do-it-yourself stores. If you do have not the necessary tools for one of the task, you can leave the work to your dealer.

6.2 Regular lubrications and maintenance

NB : An annual global check of the bike must occur only in case no check has been done in the year. The operations preceded by an asterisk can only be carried out by people specially trained, with the required tools. In fact, it would be safer to delegate the complicated maintenance to them.



Part	Opération	After use	Every 3 months	Every 3months	Every year	As required
Piston	Inspect and clean		<input checked="" type="checkbox"/>			
	Replace					<input checked="" type="checkbox"/>
Piston ring	Inspect and clean			<input checked="" type="checkbox"/>		
	Replace				<input checked="" type="checkbox"/>	<input checked="" type="checkbox"/>
Cylinder head	Inspect and clean			<input checked="" type="checkbox"/>		
	Replace					<input checked="" type="checkbox"/>
Cylinder	Inspect and clean			<input checked="" type="checkbox"/>		
	Replace					<input checked="" type="checkbox"/>
Clutch	Inspect and clean			<input checked="" type="checkbox"/>		
	Replace					<input checked="" type="checkbox"/>
Gear box	Inspect and clean		<input checked="" type="checkbox"/>			
	Change oil				<input checked="" type="checkbox"/>	
carburetor	Inspect and clean		<input checked="" type="checkbox"/>			<input checked="" type="checkbox"/>
	Tune					<input checked="" type="checkbox"/>
Spark plug	Inspect and clean	<input checked="" type="checkbox"/>				<input checked="" type="checkbox"/>
	Replace					<input checked="" type="checkbox"/>
Chain	Greasing and tension	<input checked="" type="checkbox"/>				
	Replace					<input checked="" type="checkbox"/>
Radiator	Inspect and level	<input checked="" type="checkbox"/>				
	Replace liquid			<input checked="" type="checkbox"/>		
Air filter	Clean and Greasing	<input checked="" type="checkbox"/>				
	Replace		<input checked="" type="checkbox"/>			<input checked="" type="checkbox"/>
Brake	Inspect and tuning	<input checked="" type="checkbox"/>				
Fork	Inspect and tuning	<input checked="" type="checkbox"/>				
	Change oil				<input checked="" type="checkbox"/>	
Shock absorber	Inspect	<input checked="" type="checkbox"/>				
	Replace					<input checked="" type="checkbox"/>
Swing arm	Inspect	<input checked="" type="checkbox"/>				
	Greasing		<input checked="" type="checkbox"/>			<input checked="" type="checkbox"/>
Tires	Inspect	<input checked="" type="checkbox"/>				
	Replace					<input checked="" type="checkbox"/>
Throttle	Inspect	<input checked="" type="checkbox"/>				
	Greasing		<input checked="" type="checkbox"/>			<input checked="" type="checkbox"/>



NB :

- The 'unusual' conditions of use must imply the increase of the maintenance frequency. All the parts which have to be lubricated or greased are concerned, as far as the air filter, which needs to be more frequently and after all "off road" ride. Those conditions are the rain, the humidity, the sand or the dust.
- The SY250 is equipped with two hydraulic disk brakes, which require a special maintenance :
- Replacement of the brake master-cylinders components and callipers and the brake fluid change every two years.
- Replacement of all brake hoses every four years or as soon as they are cracked or there is a fluid leak.
- After all "off road" ride you must carry out all the controls indicated in this table.

6.3 Spark plug check

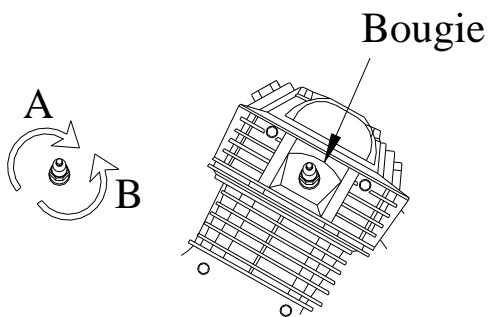

The spark plug has one of the essential roles in the functioning of the engine. That is why it is really of the primordial importance to check its state as often as written in the list. Bad adjustments, the heat and all the deposits can all damage the spark plug. For this bike, SCORPA recommends to use the following model NGK CR7HSA

In order to take the spark plug off, follow those two stages :

1. Take off the anti-interference system
2. Unscrew the spark plug in the direction (B) thanks to a spark plug spanner.

The spark plug state check consists in two stages too :

1. Make sure the porcelain colour around the electrodes is dark or light coffee coloured, because that colour shows the spark plug works in good conditions.
2. Check the weakening level and that the carbon deposits thickness are not excessive. If one of those situations happens, it is time to replace the spark plug.

There are four phases in the spark plug reassembly :

- Measurement of the electrodes gap, thanks to a wedge whole set. If needs be, adjust to the recommended value: 0,6 to 0,7mm

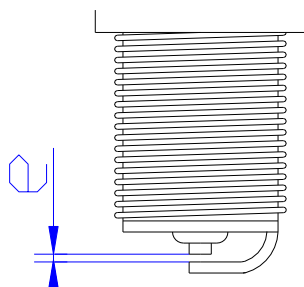



2. Clean the joint surface and the spark plug thread.

3. Put the spark-plug in the cylinder-head. Then begin to tighten it with the hand, in order not to damage the head cylinder tapping (direction A). Tighten the spark plug thanks to torque wrench: the recommended torque is : 17.5 Nm (1.75 m.kgf).

If you have not got this tool, the solution is to tighten with the hand at the most, before to tighten from ¼ to ½ turn with a usual wrench. After that, adjust to the recommended torque with a torque wrench as soon as possible.

4. Put back the spark plug cap.

6.4 Engine oil

It is imperative to check the engine oil level before every use. The lack of engine oil can cause an insufficient lubrication of the moving parts as far as a superheating. The list of regular maintenance and lubrications gives you the recommended frequency for each task. For a greater longevity of the engine, use the oil **100 % synthèse-ester-SAE 10w40**.

6.5 Engine oil level check

- 1) Start the motorcycle and let it turn during 5 minutes.
- 2) The bike must be situated on the most horizontal ground and it has to stand upright.
- 3) The control is made at the level of the gas cap of oil, on the right crankcase of the engine, the level that must be situated between marks MIN and MAX; with the engine cold.

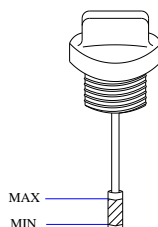

- 4) In case there is not oil enough, add oil up to the recommended level. The oil filling up hole is on the top of the right crankcase.

Oil change :

- 1) Start the engine and let it warm up for a few minutes, and after that switch it off.
- 2) Put an oil change tray under the oil drain plug. It will help you to collect the old oil.
- 3) Unscrew the cap and the drain plug. The oil should begin to flow.
- 4) Once all the evacuated oil of the engine, screw up the drain plug.
- 5) Fill the engine with *100 % synthèse-ester-SAE 10w40* by the opening of filling by taking care to check the oil level with the stopper of filling.
- 6) Start the engine and to let it heat a few minutes, then to switch it off.
- 7) Check the oil level again (see paragraph on the control of the oil level).



6.6 Air filter cleaner

In order to keep the high level of performances of the bike and its reliability, it is essential to clean regularly the air filter, following the indications given by the list of regular checks and maintenance. As it has already been advised, the cleaning must be more frequent if the atmospheric and use conditions are humid or dusty.

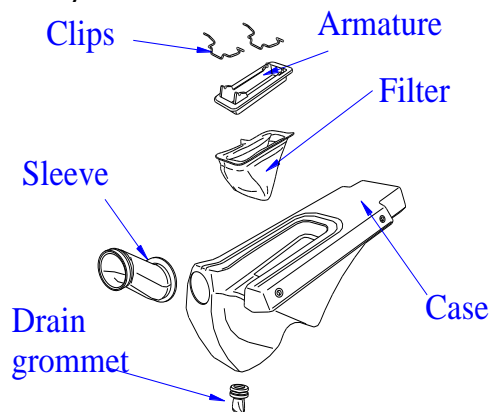

The stages to be followed are enumerated here:

- 1) Removal of the saddle: to remove the screw which fix the saddle to the back mudguard.. Disconnect the bottom of the saddle and the brace by pulling the saddle towards the back of the motorcycle.
- 2) Removal of the rear fender: unscrew the 2 screw behind the rear fender, then the one who shows solidarity the fuel tank and the rear fender, who can be then removed. Do not forget to disconnect the pod of the electric bundle.
- 3) Make both metal clips revolve which block the air filter in the case. It is now possible to remove the plastic rectangular armature and the air filter.
- 4) Separate the element in foam and clean it with a grease remover for air filter. The elimination of the solvent is made by pressing the foam. Especially not press it, because it risks to tear.
- 5) Coat the foam of the oil of air filter, then eliminate the excess by pressing again the filter.
- 6) Verify the cleanliness and the absence of humidity in the case-filter. If need, to remove the unwanted particles and to dry with a clean and dry cloth.
- 7) Pinch the rubber of draining of the case-filter and verify that it is not filled. If necessary, uncork the rubber with a tool which does not risk to tear it or to disconnect it from the case. Otherwise, clean it then put it in back in place.
- 8) Replace the filter in foam, the armature and fix them in the case thanks to both metal clips.
- 9) To reconnect the pod of the electric bundle then to replace the rear fender by beginning with the brace and saw it which connect it to the fuel tank. To place both lived behind the rear fender.



6.7 Carburetor adjustment

The carburetor is one of the essential parts for the functioning of the engine, in order to have the best performances, and to increase the engine reliability. It needs to be very precisely adjusted, preferably by a professional especially trained and tooled.

Regulation of the regime of slow motion of the engine:

This operation must be led, so necessary, to the periods indicated by the board of the controls, the greasings and the periodic maintenances. Attention, this regulation is made exclusively driving warm. This operation requires the use of a rev-counter of diagnosis.

- 1) Fix the rev-counter of diagnosis in the course of the candle.
- 2) Check(control) the regime of slow motion, and, if need be, correct it in the vale

6.8 Play of the valves

As the time goes along, the play of the valves changes and it may alter the ratio of air to fuel of the inlet air-fuel mixture.

The solution is so to make it adjust by your dealer, as often as written in 'List of the regular maintenance and lubrications'.

It is a really complicated operation, which requires a professional expertise.

Valves clearance (cold):

- | | | |
|-----------|-----------------|-----------------------|
| - Intake | 0.08 to 0.12 mm | (0.0031 to 0.0047 in) |
| - Exhaust | 0.10 to 0.14 mm | (0.0039 to 0.0055 in) |

6.9 Wheel-axle units

6.9.1 Front wheel removal

1. Loosen the front wheel-axle and the screws on the bottom of the front fork arms.
2. Lift the front wheel, by using a raising stand or by putting a jack under the engine protection. Take care the bike is stalled enough to prevent it from overturning.
3. Remove successively the axle and the wheel.

6.9.2 Front wheel fitting

1. Lift the wheel up within the two front fork arms, and make sure the brake disk is situated within the brake pads.
2. Thread the wheel axle through the two front fork arms, the speedometer mechanism, and the wheel hub.
3. Tighten the axle to the recommended torque: **30 Nm (3,0 m.Kgf)**.
4. Tighten the screws on the bottom of the front fork arms.

6.9.3 Rear wheel removal

1. Loosen the wheel axle nut.
2. Turn the two chain tension eccentrics in the direction which allows the wheel to move towards the front of the bike.
3. Lift the rear wheel, by using a raising stand or by putting a jack under the engine protection. Take care the bike is stalled enough to prevent it from overturning.
4. Remove successively the axle nut and the axle.
5. Make the wheel move to the front of the bike, and remove the chain from the rear sprocket.
6. Remove the rear wheel from the swinging arm.



6.10 Tires

Here are the different principles to follow, with the aim to improve the use life, the performances and the security of your tires.

- Air in the tires : it must be checked and adjusted before each use :

Recommended pressure (checks on cold tires)	
Front tire	Rear tire
100kPa (1,0kgf/cm ² ; 15 psi)	120 kPa (1,2kgf/cm ² ; 18 psi)



WARNING

The load carried by the vehicle has an important impact on the engine performances, on the braking, on the suspension, but first and foremost on the road holding and on the tyres performances. To avoid risks at the maximum, a few precautions have to be taken:

- DO NOT EXCEED THE TECHNICAL MAXIMAL LOAD. That could damage the tyres, and even the lost of control by the rider so that an accident could happen.
- Make sure meticulously that the transported objects are efficiently stowed. Try to place the heaviest objects near the center of the bike, and check they are well shared out among the left and the right.
- Adapt the air in the tires to the transported load.
- The air in the tires, their condition and the depth of their treads must be checked before each use.

6.10.1 Check of the conditions and of the treads depth of the tires

Some conditions must imply the replacement of the concerned tire:

- If the depth of the treads has reached the minimum legal value,
- If there are one or some foreign bodies (nail, glass or metallic fragments) inlaid in the tire,
- If the flanks of the tire are cracked.

NB: the minimum depth of the treads is not the same everywhere in the world. That is why it is advisable to respect the legal value of the Country where you are riding.

6.10.2 Pieces of information about the tires

- The front and rear tires are preferably from the same manufacturer, with the same structure, with the aim to improve the road holding.
- Here are the different tires which are homologated for the SCORPA SY 125 FR et SY 200 FR :

FRONT :

Mark	Dimensions	Model
MICHELIN	2,75-21"	Trial competition

REAR :

Mark	Dimensions	Model
MICHELIN	4,00-18"	Trial competition



6.11 The spoke wheel

The normal functioning of the bike, its reliability and the security depend on the following precautions:

- Before each use, check the lack of cracks on the rims
- Check the spoke tightening and tighten it again if necessary as explained in the dedicated paragraph.
- Make sure the wheel is not buckled.
- Every time the tire or the rim is replaced by another, it has to be rebalanced. A non-balanced wheel disrupts the road holding and shortens the length of the use life.
- After the tire replacement, it is advised not to ride too fast, until the tire is well run.



WARNING

Never try to repair an old and cracked or a buckled rim! It must imperatively be replaced by a new one

6.12 Transmission chain

The tension of the transmission chain has to be checked before each use, and adjusted if it needs to be.

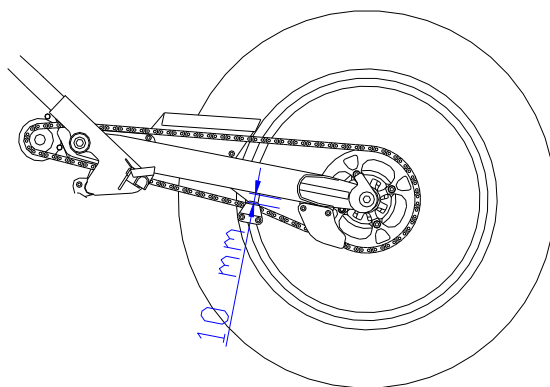

6.12.1 Check of the tension

1. Place the bike on a horizontal area and set it upright. Careful! There must not be any load on the bike, during the checks.
2. Put the gearbox in neutral.
3. Make the bike move forward, in order to locate the place where the tension is at its maximum.
4. Check the distance between the rubber chain-adjuster and the swinging arm as shown on the diagram. The distance must be bounded by 9 and 11 mm.

6.12.2 Setting

1. Loosen the rear wheel axle.
2. To tighten the chain, turn the left eccentric clockwise (c) and the right one anticlockwise. On the contrary, to release the chain turn the right eccentric clockwise (c) and the left one anticlockwise, then push the wheel towards the front of the bike, until the eccentrics lean on their stop on the swinging arm again.
3. Tighten the wheel-axle nut to the recommended torque: **60 Nm (6,0M.Kgf)**.

NB: The two eccentrics must be adjusted exactly in the same way and the same position, to keep the wheel aligned with the rest of the bike.



WARNING: if the chain is not tightened enough, it can cause chain jumps and even the wheel locking, which imply the risk to make the rider fall. Moreover, that includes very strong stresses on the transmission parts (chain, sprockets) and on the engine.

6.12.3 Lubrication

It is essential to clean and lubrication the chain as often as said in the 'List of the regular maintenance and lubrication'. Otherwise, the chain will deteriorate quickly, particularly if you ride in humid and dusty areas.

- After the first cleaning of the bike, brush out the mud and the grime thanks to an old piece of rag or a brush.
- Spray **Motul chaine lub off road** for transmission chain onto the chain, on both sides and on the top of the chain, to lubricate at best all the rolls.

6.13 Adjustment of the clutch lever loose

The clutch lever play must be bounded by 10 and 15 mm as shown on the following diagram. It has to be checked and adjusted before each use. Here is the process:

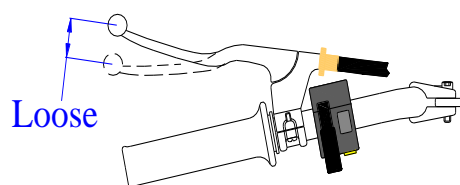

- Loosen the lock nut of the clutch lever.
- To increase the loose, turn the screw clockwise. To reduce it, turn it anticlockwise.
- Then there are two possibilities. In case the adjustment is efficient and sufficient, tighten the lock nut. In case not, ask your dealer to adjust it.

6.14 Brakes

6.14.1 Adjustment of the brake levers loose

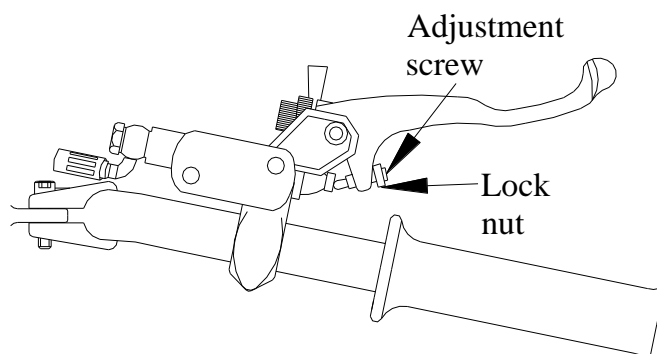



The front brake lever loose must be bounded by 5 and 8 mm. The way to measure it is the same as for this of the clutch lever. It has to be checked and adjusted before each use. Here is the process:

Loosen the lock nut of the brake lever.

- To increase the loose, turn the screw clockwise. To reduce it, turn it anticlockwise.
- As soon as the recommended loosed is reached, tighten the lock nut. In case you do not manage to adjust it, ask your dealer to adjust it.



WARNING

The new plates must be ground, so that the brake provides optimal proportioning and best deceleration. For that, make about thirty accelerations until approximately 30km/h, and slow down gradually until the total stop.

6.14.2 Adjustment of the rear brake pedal loose

The loose of the brake pedal must be bounded by 20 and 30 mm, as shown on the diagram. It must be checked regularly and adjusted to the recommended value, if necessary.

Loosen the lock nut of the brake pedal.

- Tighten the setting screw to increase the loose, and loosen it to reduce the loose.
- As soon as the good loose is reached, tighten the lock nut of the brake pedal.

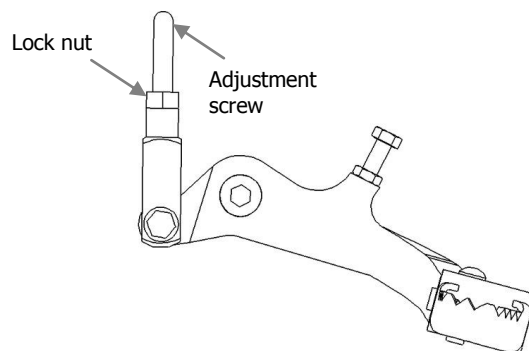

WARNING

- Check the functioning of the front brake every time you adjust the lever loose.
- If the lever gives a feeling of being spongy, it is probably due to air bubbles in the hydraulic circuit. You need confide the bleeding of the brake circuit to your dealer, to avoid a loss of braking efficiency.
- If the needed loose can not be reached, confide this task to your dealer.

6.14.3 Pad wear control

Take care to check the brake pads wear, in accordance to the frequency given by the 'List of the regular maintenance and lubricating :

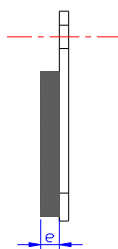



Make sure that the thickness of the brake pads lining is sufficient. It must not be less than 1mm. Otherwise, make the pads replaced by your dealer and your brakes adjusted.

Contrôle du niveau de liquide de frein :

6.14.4 Brake fluid level control

If the level of brake fluid is not sufficient, that may create air bubbles in the hydraulic circuit, so that the brakes could work badly. The consequences could be very serious for the rider.

The regular check (before each use of the bike) and the filling up are essential.

The fall of the brake fluid level may be caused by an excessive pads wear or by bubbles in the hydraulic circuit. In this case, it is recommended to make sure the circuit is not cracked and there is no leak too.

A few precautions will help you to check and maintain at the best the brake circuit of your bike

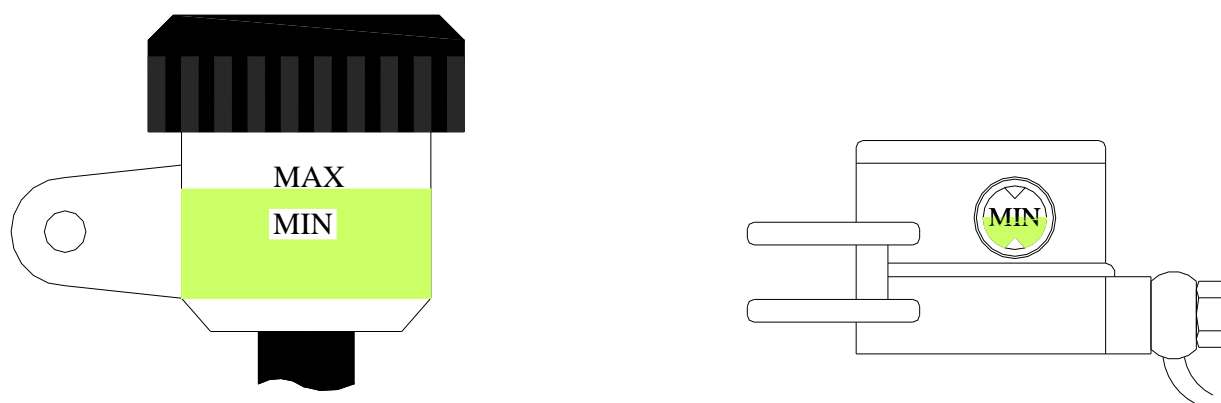

- The check of the brake fluid level must be operated when the top of the fluid tanks is horizontal, with the aim not to alter the level measurement.
- The filling up has to be operated with the recommended brake fluid: **Motul Brake Fluid DOT 5.1**, and the same type as this of the fluid of the circuit, to avoid the risk of chemical reaction.
- It is essential not to introduce bubbles of air in the brake fluid, because it could decrease the fusion temperature and to create steam in the circuit.
- Be careful not to let brake fluid flow on plastic or painted parts during the filling up: wipe carefully with a soft piece of rag.

6.14.5 Brake fluid change

The brake fluid change must occur in accordance with the indications given in the 'List of the regular maintenance and lubricating

It is preferable to confide this task to your dealer, and ask him to replace the collar joint of the master cylinder and of the caliper, as far as the brake fluid hose, following the recommended frequency and in case of leak of fluid.

- collar joint : replace every two years
- brake hose : replace every four years



6.15 Lubrications

6.15.1 Cable

The accelerator cable, the choke and clutch cables have to be checked before each use. So a good functioning of the controls is obtained and it is easier to detect all dry and damaged cables.

In case the cable is damaged, if the functioning is uneven, if the progressiveness of the control is insufficient or if the cable is damaged, it is vital to replace the defective part.

It is important to lubricate the cable as shown on the diagram, to the frequency given in the 'List of the regular maintenance and lubricating ; recommended lubricant: *EZ Lube multi protect*

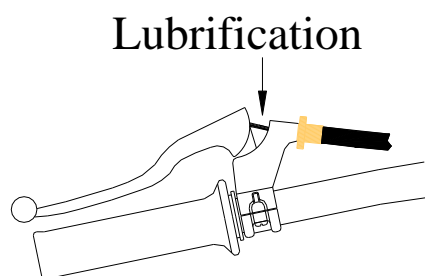

6.15.2 Brake pedal, gearshift levers

The functioning of those controls must be given much care and needs to be checked before each use. If it needs to be, lubricate the articulations with the recommended lubricant, which is: *Motul Tech Grease 300*

6.16 Side stand

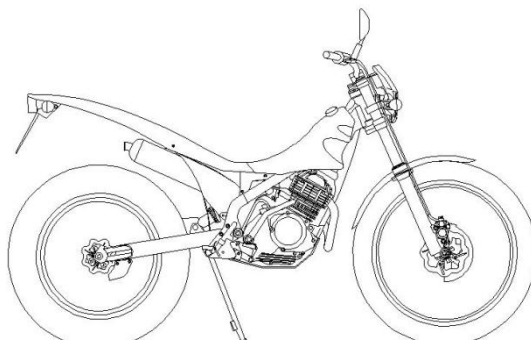

Just as for the levers, the functioning of the side stand has to be checked before each use. In fact, a bad functioning can prevent the side stand from folding up. If the stand does not totally fold up, it can make the driving very dangerous.

If needs be, lubricate the articulation of the stand as far as all contact surfaces, which take part in the rotation, with **EZ Lub multi protect**.



WARNING

If the side stand does not work properly despite the lubrication, it is strongly recommended to make it check by your dealer. If it needs to be, replace the defective part.



6.17 Rear suspension

6.17.1 Inspection

- Check for a broken or collapsed spring.
- Check the suspension action by bouncing the rear of the machine.
- Check the rear shock absorber for a bent shaft or oil leaks. If there is a problem, make it inspect by your dealer, and replace it if there is a serious problem.

6.17.2 Adjustment

The swingarm is controlled by a shock absorber. It's also possible to be adjusted for the rider's weight and track conditions.

- Spring pre-load : turning the spring pre-load adjuster adjusts the spring initial pre-load length.
- Rebound damping : turning the screw adjusts how quickly the shock absorber extends.

6.18 Front fork and steering

6.18.1 Front fork check

Check the condition of the front fork pipes (lack of scratch, of claw mark or of damage) and the lack of fork oil leak. If there is one, it must be minor. Otherwise, the fork has to be inspected by your dealer, then repaired or replaced.



WARNING

This operation requires putting well the bike on blocks to prevent it from overturning.

6.18.2 Check of the functioning of the fork

1. Place the bike the most vertically possible, on a horizontal area.
2. Operate a few times the front brake (in order to stop the bike from moving) while you compress strongly the front fork by pressing on the handlebar. So it is easier to check the progressiveness of the fork during the compression and the release.

WARNING : if the functioning or the progressiveness of the front fork is not satisfactory, make it inspect by your dealer, and replace it if there is a serious problem.

6.18.3 Check of the steering

It might happen that the steering bearings are loose or damaged. Then they may cause serious dysfunction in the steering. That is why the owner is expected to check it as often as possible (look at the 'List of the regular maintenance and lubrications').

Here are the different operations to follow :

1. Put the bike on blocks to allow you to lift the front wheel off the ground. A wedge placed under the engine protection is the simplest solution. Make sure the bike will not overturn during the operation.

2. Hold one fork pipe a hand and try to make them move forward and backwards many times. If a loose appears, ask your dealer to check it, and to repair or replace the defective parts if necessary.



6.19 Check of the wheel bearings

Check the condition and the progressiveness of the wheels bearings in accordance with the pieces of information of the 'List of the regular maintenance and lubrications'. In case the buckles have loose, or in case the wheels do not revolve well, it has to be inspected and maybe repaired or replaced by an occupational mechanic.

6.20 Replacement of electric elements

6.20.1 Replacement of a light bulb

If one of the bulbs is dud, you can replace it, by following the instructions:

- Undo the two screws of the head light.
- Remove the light of the headlight.
- Separate the bulb support from the light.
- Remove the dud bulb by pressing on it while you turn it, until the bulb is pulled away.
- Put a new bulb on the bulb support, press on it and turn clockwise, until the bulb is stopped into the support.
- Put back the bulb support on the light.
- Replace the light on the headlight and tighten the two screws.

WARNING:

- The bulb becomes hot very quickly after the beginning of its use. To avoid the risks of burns and inflammation, it is essential to hold the bulb with a piece of rag and to operate far away from the sources of heat and flames.
- The glass of light bulbs must absolutely not be touched by the fingers, in order not to let greasy deposits. In fact they reduce the transparency of the glass so that the light beam is not as intensive as it is expected to be. Clean the traces with a soft duster, alcohol or solvent, AFTER THE COMPLETE COOLING OF THE BULB.

6.20.2 Replacement of the indicators bulbs

- Remove the screw of the indicator orange lens.
- Remove the dud bulb by pressing on it while you turn it, until the bulb is pulled away.
- Put a new bulb on the bulb support, press on it and turn clockwise, until the bulb is stopped into the support.
- Put back the orange lens on the indicator and tighten the screw. Do not tighten too much strongly, because the plastic part might become fragile after some removals.

6.20.3 Replacement of the rear light bulb

- Remove the two screws of the rear light red lens.
- Remove the dud bulb by pressing on it while you turn it, until the bulb is pulled away.
- Put a new bulb on the bulb support, press on it and turn clockwise, until the bulb is stopped into the support.
- Replace the red lens on the rear light. Then tighten the two screws.



6.21 Diagram of breakdowns and dedicated checks

Despite the care, the complete check list, the static and dynamic checks, the quality controls led by SCORPA during the development and the manufacturing of its bikes, a breakdown could happen. A problem could cause difficulty for the start out, a loss of performance or an abnormal functioning. The following diagram gives some pieces of information about the checks you could operate, in order to set better the probable reasons for the breakdown.

If any important operation has to occur, it is strongly recommended to confide it to your dealer, who is especially trained therefore.

Moreover, the replacement of the defective parts has to be operated with SCORPA's parts, which ensure the best reliability and performances. Those are parts which have been jointly designed especially for your vehicle. The reputation of quality and sturdiness is firmly established.

The quality and sturdiness of the 'adaptable' parts is so very often lower. Then they will lead to additional cost in short or medium term, or to damages and repairings very expensive.

6.21.1 Fuel

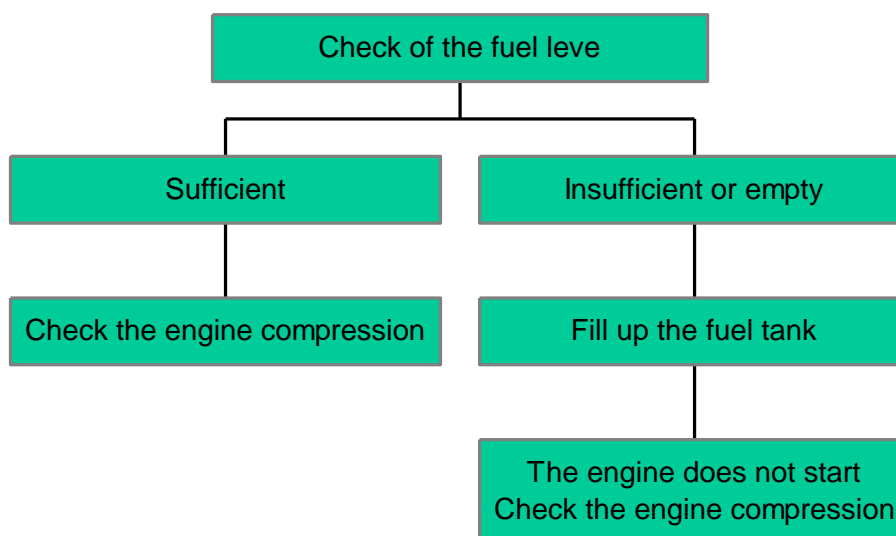

6.21.2 Compression

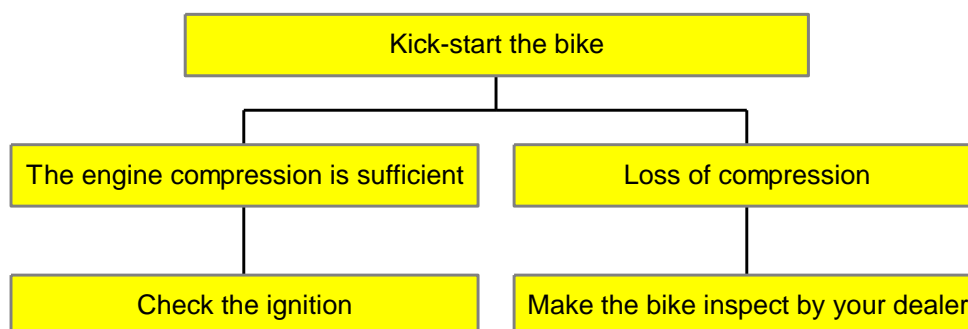



6.21.3 Ignition

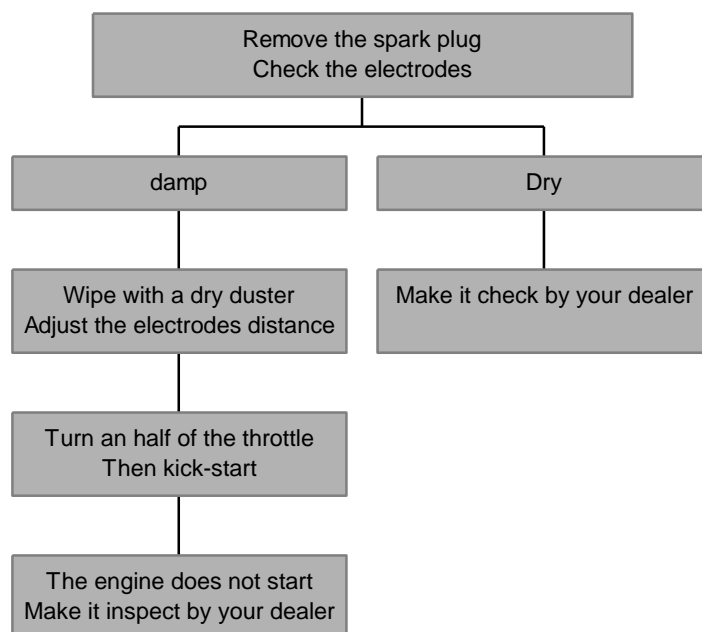

7 CARE AND STORING OF THE BIKE

7.1 Care

The lack of coachwork exposes almost all parts of the bike to the stresses of the surroundings. The impacts caused by the throwings and the scratches weaken the surface of the parts, even if those of the best quality. Then they could begin to corrode and tarnish

A regular maintenance permits the parts not only to keep their original appearance and their level of performance, but to assure the length of their use-life too. Moreover, the regular maintenance of the bike is the necessary condition to be sure the recourse to the guarantee will be possible.

7.1.1 Before cleaning

- Make sure the electric terminal spade tags, the spark plug cap and all caps are well protected and positioned.
- Wait for the cooling of the engine and all warm parts.
- Put a watertight cap on the exhaust silencer end.
- It is possible to use a brush and a spot remover only in case it is never brought into contact with the joints, the axles, the bearings, the sprockets and the chain. It is essential to rinse thoroughly with water.

7.1.2 Cleaning

WARNING :

- All the parts made of plastic or rubber have to be cleaned by soft sponges or pieces of rag, water and **Moto Wash Motul**. It is forbidden to use acid or basic chemicals.
- SCORPA strongly advise against high pressure or vapour cleaners. In fact an important amount of water could infiltrate joints, bearings, electric components or the airbox. The bike is only expected to work in atmospheric and ground humidity. The high pressure or vapour cleaners would cause serious dysfunctions or damage several parts.



The cleaning is different according to the conditions and the area of use. The classic one is made of warm water and **Moto Wash Motul**. It has to be followed by a copious water rinsing.

If the bike is used in particular conditions or if the air level of salinity is high, the way to clean the vehicle is a little bit different:

- Cleaning with cold water and **Moto Wash Motul** as soon as the bike is cooled.
- Protection against corrosion of all metallic surfaces (even if they are chromium-plated or anodized) by spraying **Motul EZ Lub Multi Protect**.

7.1.3 After the cleaning

- The drying of the bike has to be as quick as possible. If it is not the case, dry it with a soft piece of rag.
- As soon as the bike is dried, lubricate the chain with **Motul Chaîne lub Off Road** and all parts which could corrode.
- Scrub the chromium-plated or anodized metallic surfaces with a clean piece of rag and an anticorrosion chemical.
- Do not cover and store the bike before it is totally dry.

7.2 Putting away

Here are explained two different ways to put away the bike, according to the length of non-use. If it is short enough, about a few days, all you have to do is store the bike in a dry and fresh place. If this place is dusty and if animals could damage the bike, cover it with a porous dust cover.

For a longer period, it is recommended to follow those instructions:

- Clean the bike as explained in the previous paragraph.
- Remove the switch key and position all controls on 'OFF' (fuel tank tap, choke, light controls).
- Empty the carburettor tank by loosing the drain plug and use **Motul Carbu Clean**. That is expected to fight against the formation of deposits. Another solution consists in putting the fuel tap on 'OFF' while the engine is still running, so that the engine stops a few seconds later. Make sure the bike is totally cooled before putting it away.
- If possible, add a fuel stabilizer in the tank to prevent the fuel from deteriorating.
- Respect the following recommendations to allow the engine to be protected :
 - A. Remove the spark plug and its cap
 - B. Pour about 3 centilitres of engine oil in the spark plug hole.
 - C. Operate several times and very slowly the kick-start in order to spread the oil everywhere in the engine.
 - D. Replace the spark plug and its cap.
- Lubricate all cables, levers, pedals, gearshift lever, side stand and articulations with **Motul EZ Lub Multi Protect**.
- If possible, it is preferable to heighten the bike, so that the humidity is not concentrated in the same place of the tyres.

Put a cap on the end of the exhaust pipe. Store the bike in a fresh and dry place. If this place is dusty and if animals could damage the bike, cover it with a porous dust cover.



8 DESIGN FEATURES

Modèle SY 125 FR
SY 200 FR

Dimensions

Overall length 2000mm
Overall width 815mm
Overall height 1130mm
Seat height 680 mm
Wheelbase 1332 mm
Ground clearance 280 mm

Basic weight

Engine

Type 4 strokes
Essence
Refroidi air
SOHC
Cylinder arrangement mono, incliné
Displacement 124 cm³
Bore * stroke 54 x 54 mm
Compression ratio 10,0 : 1

Embrayage

Transmission

Primary reduction Gearing
System
Rate reduction 68/20 (3,40)
Secondary reduction Chain drive
system
Rate reduction 57/14 (4,07)
Transmission type Constant mesh,
5 speeds
Operation left foot
Rate reduction 1st : 37/14
2nd : 29/15
3rd : 25/19
4th : 23/22
5th : 21/29

Chassis :

Frame type Perimetral

Engine oil : 100 % synthetic

Type
.-10 à 30°C : SAE 10W/30
.-10 à 40°C : SAE 10W/40
.-0 à 40°C : SAE 15W/40
.-5 à 40°C : SAE 20W/40
.-5 à 50°C : SAE 20W/50

Air filter wet type

Fuel

Type Unleaded gasoline
Capacity 2,9 L
Reserve 1,2 L

Carburator

Fabricant MIKUNI
Model VM 20 SS

Spark

CR7HSA NGK
Gap 0,6 – 0,7 mm

Tires

Front

Type Tube type
Size 21 x 2,75"
Manufacturer MICHELIN
Model Trial competition

Rear

Type Tubeless
Size 18 x 4,00"
Manufacturer MICHELIN
Model Trial competition

Max load

180 kg

Pressure

Front 100 kPa
Rear 120 kPa

Wheels

Front

Type Spokes wheel
Size 1,60 x 21"

Rear

Type Spokes wheel
Size 2,15 x 18"



Brakes

Front

Type	Single disc, Ø 183
Operation	Right hand

Rear

Type	Single disc Ø 145
Operation	Right foot

Suspension

Front

Type	Telescopic fork
------	-----------------

Rear

Type	Swing arm
------	-----------

Amortisseur

Avant

Ressort hélicoïdal / Amortisseur à huile

Arrière

Ressort hélicoïdal / Amortisseur à huile

Shock absorber

Front damper

Coil spring / Oil

Rear damper

Coil spring / Oil

Wheel travel

Front	180 mm
-------	--------

Rear	170 mm
------	--------

Electrical

Ignition system	CDI
-----------------	-----

Voltage and wattage of bulbs

Headlight	12 V / 35 W
Rear light / stop	12 V / 21 W
Twinkling parking light	12 V / 5 W
Indicator	12 V / 12 W
Lighting instruments	12 V / 1,2 W
Witnesses	12 V / 1,7 W

Identification number

Type	Adhesive plate
Position	Steering column of the frame



9 ELECTRICAL WIRINGS INSTALLATION

9.1 Passage and connection of the main electrical wiring

Make cross the main bundle to the right of the gallows of the frame and the bundle of the comodo flashing to the left.

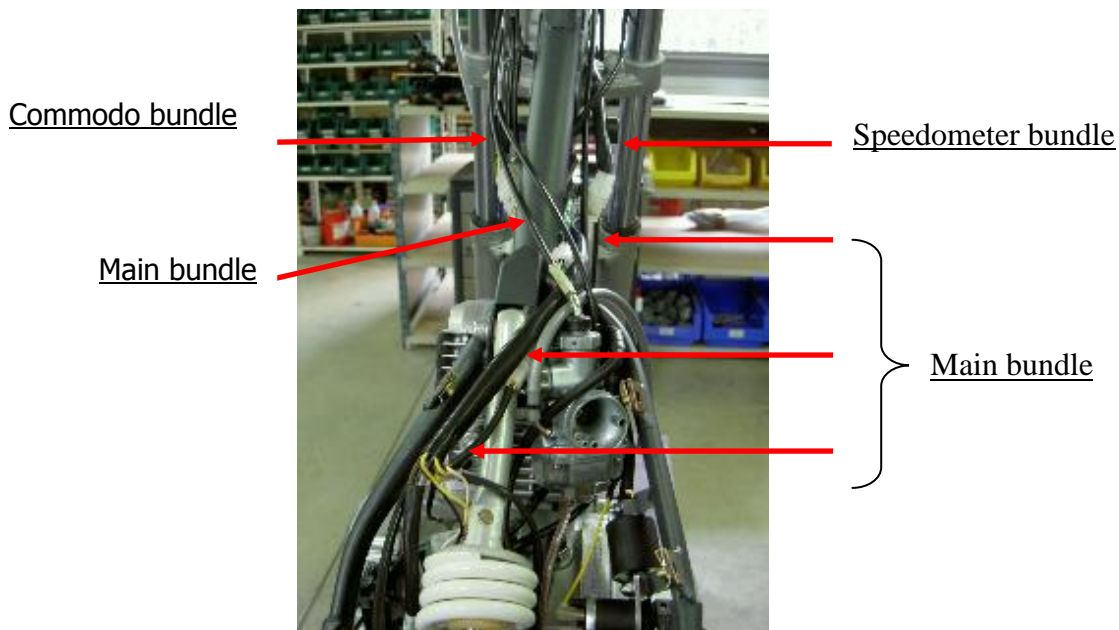

Connect the speedometer bundle to the main bundle

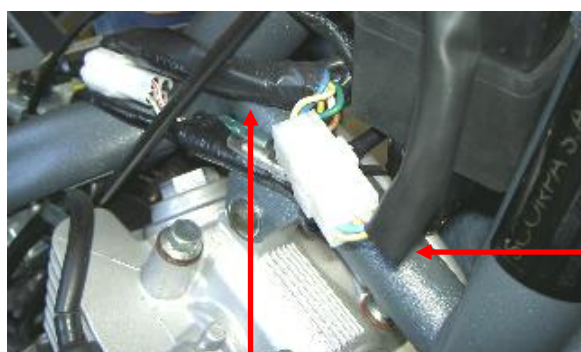

Connect the comodo bundle to the main bundle

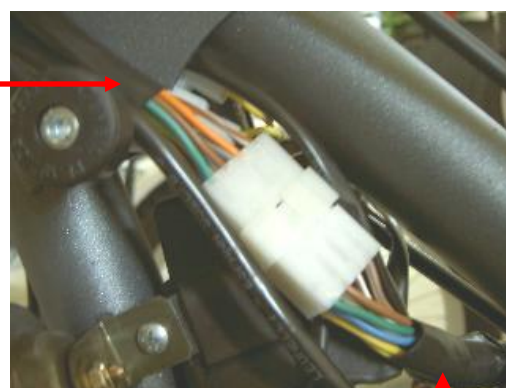



Cables and bundles have to pass behind the bindings of the fuel tank:

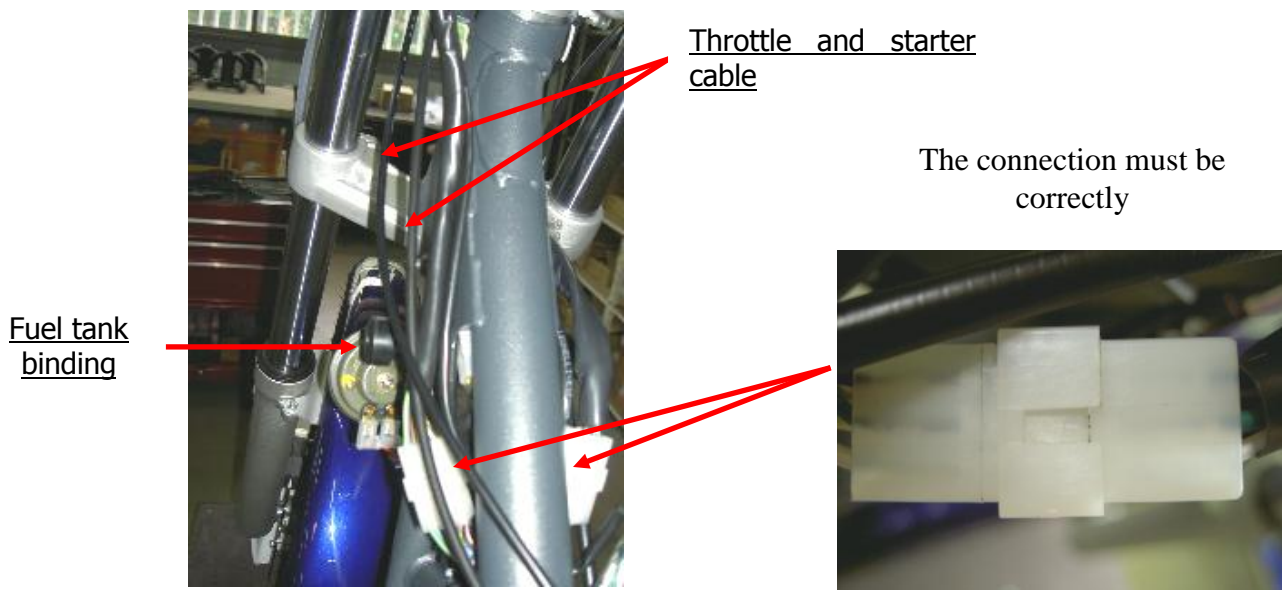

9.2 Connection of the other parts

9.2.1 Front stop light contactor

Connect the front stop light contactor bundle on the clutch lever.

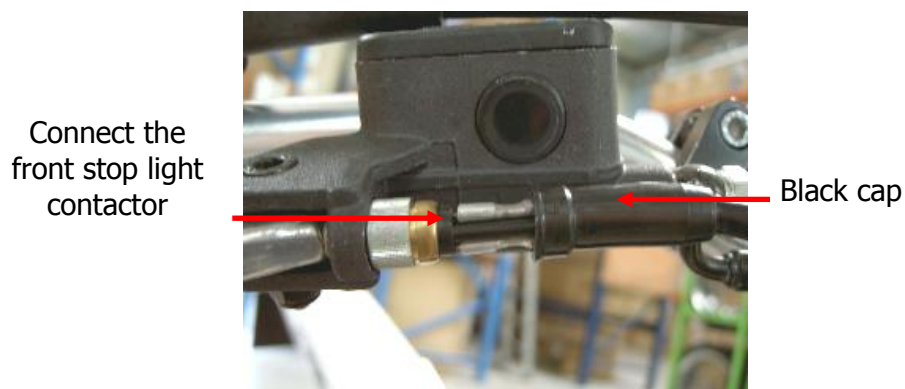



9.2.2 Rear light contactor

Fix the bundle of contacteur of the rear light with 3 rylan collar.

Ryslan collar

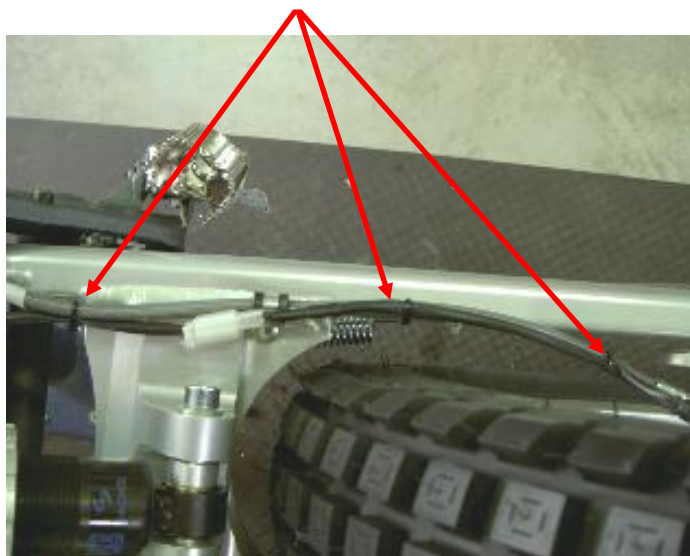

Maintain the bundle of contacteur back of rear light with the hoses of stakes in the air of the carburettor with 1 rylan collar.

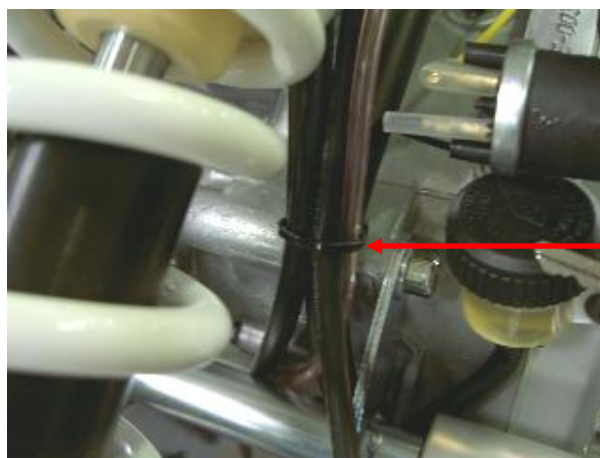

Ryslan collar

9.2.3 Klaxon

Klaxon

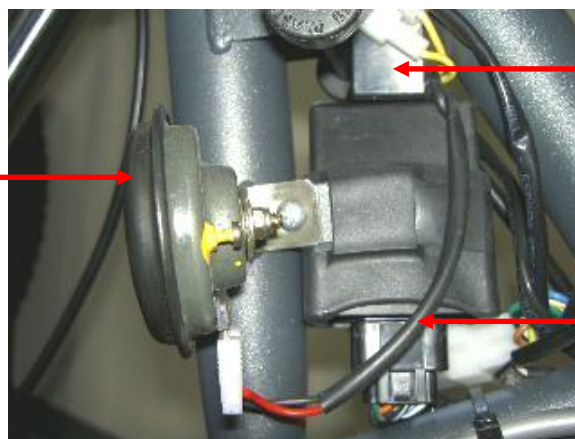

Relay klaxon

Klaxon bundle



Left view

Right view

Connexion

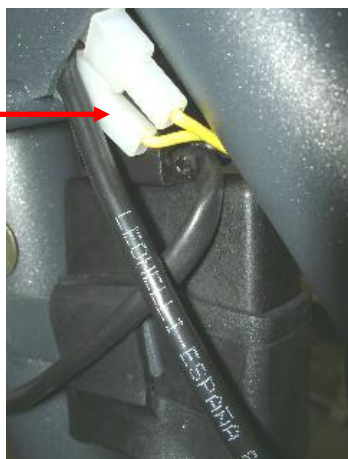

Relay



9.2.4 Direction light generator unit

Direction light generator unit



Screw fixing the direction light generator unit



Direction light generator unit represented by dotted lines is behind the spider. Indeed stick the direction light generator unit against the spider by pushing her(it) upward





9.3 Rear light

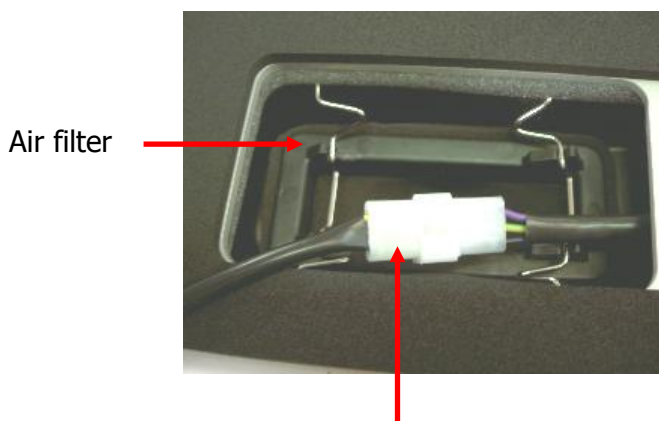

Connection of the rear light bundle



Put the rear light bundle like the picture

9.4 Reassembly and passage of cables

Right side

Left side

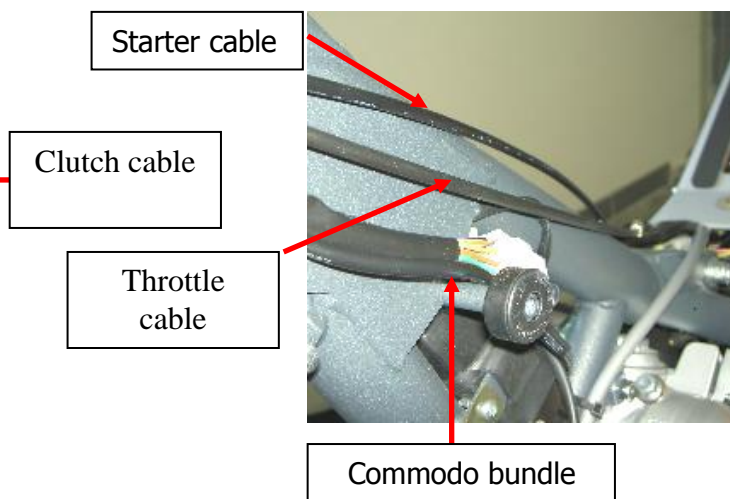
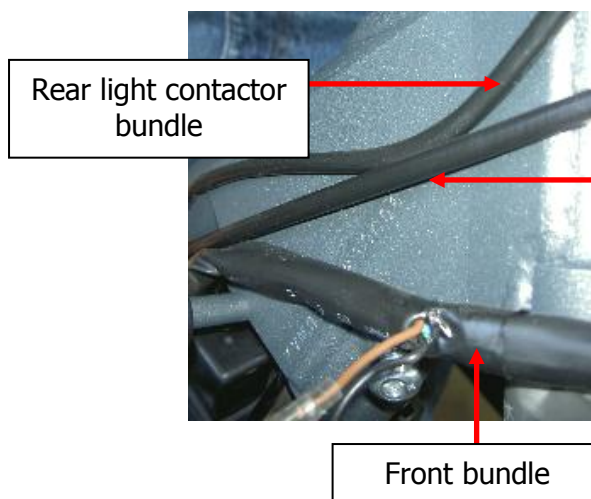

WARNING

Left side from down to up:

- Commodo bundle
- Throttle cable
- Starter cable

Right side from down to up:

- Front bundle
- Clutch cable
- Front stop light contactor bundle

Stick the bundles and the cables at the fuel tank installation time.